

# 表紙

## 年長児（5～6歳）毎日通常プリント No3-4

べんきょうはあせらずコツコツ  
まいにち コツコツ  
ふくしゅう コツコツ  
コツコツすればダイジョウブ

早寝は体が健康に  
早起きは心が豊になります。



規則正しい生活も学力

なまえ

--	--	--	--	--	--	--	--	--	--

トムはお母さんと森へ遊びにきていますが、道に迷ってしまいました。トムは森の中をさまよっているといじわるな魔法使いと出会いました。



ひとりだけがあなたの本当のお母さんです。あなたは道の曲り角を右・左・右・左・右というように曲がって行きなさい。最後に出会った人がお母さんです。

トムの歩いた道に鉛筆で線を書きなさい。そしてトムのお母さんに○を付けなさい。

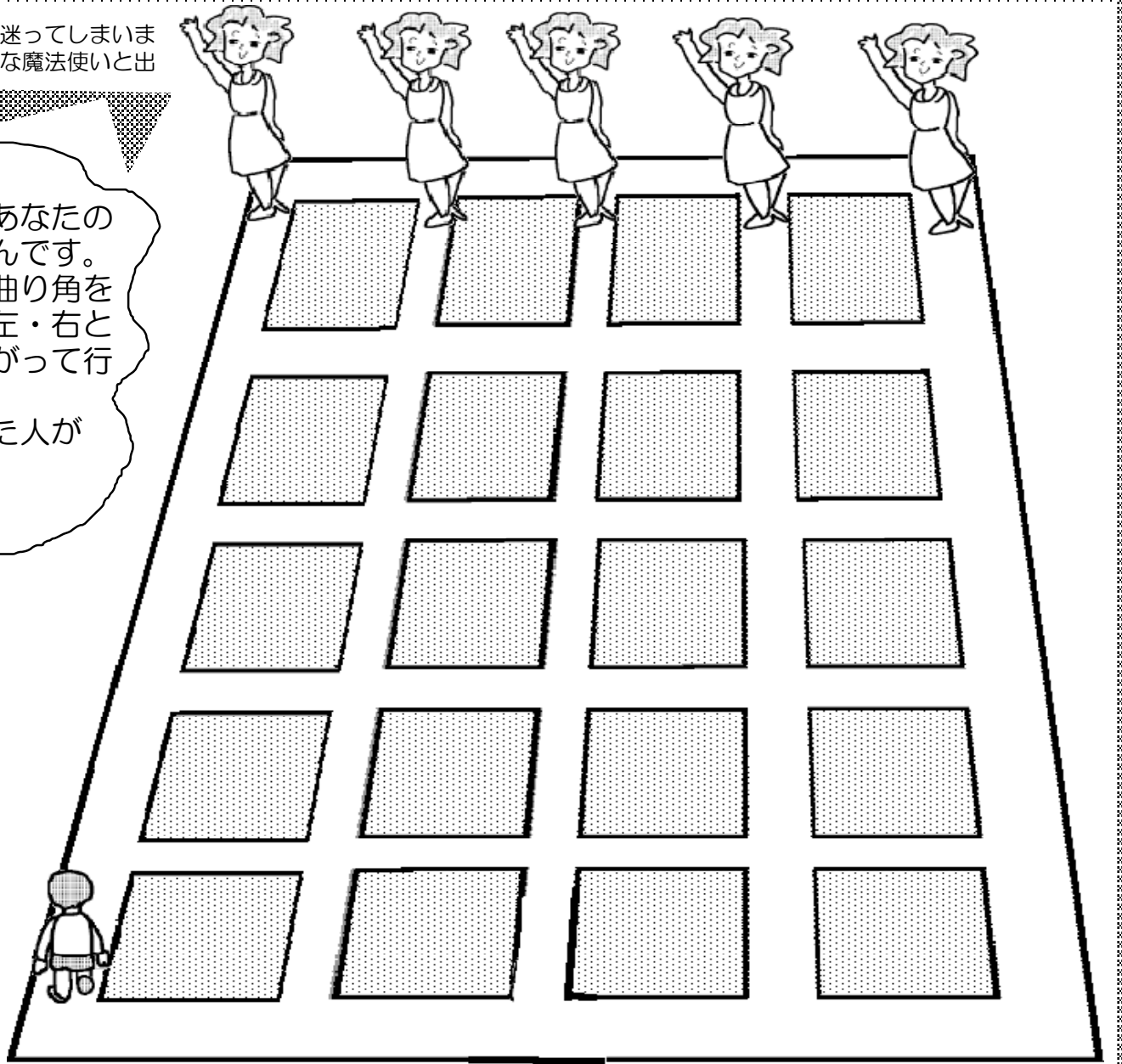

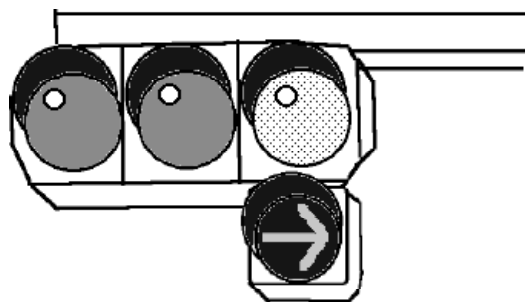

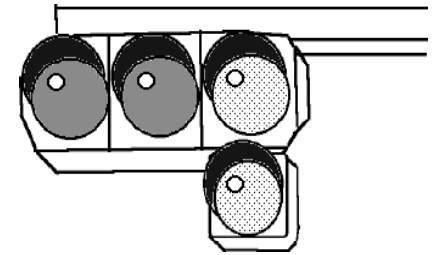
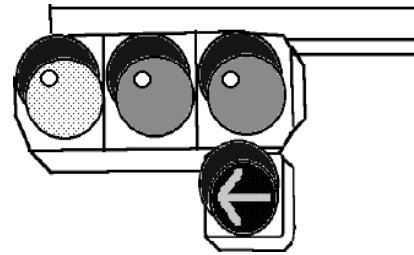
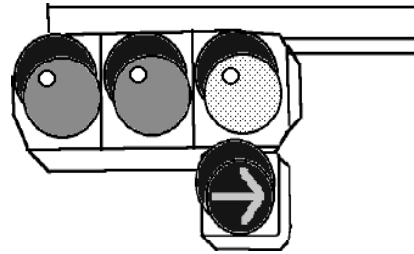
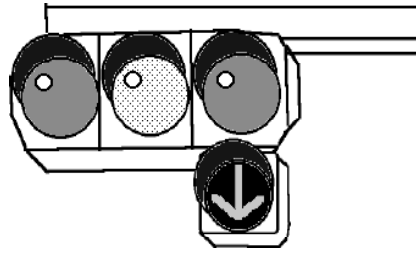

今覚えた絵に青色で○を付けなさい。

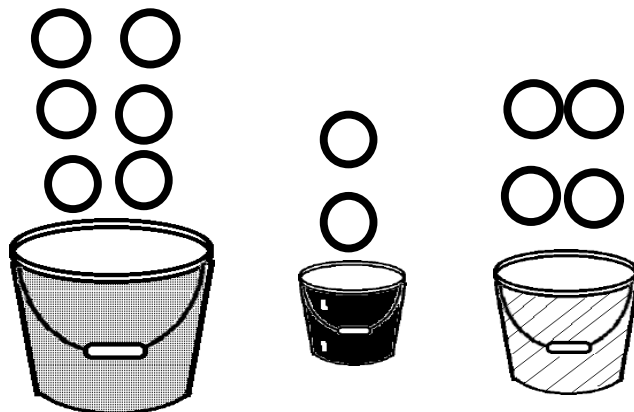

それぞれのバケツにはお約束通りのボールの数しか入りません。  
ではそれぞれのバケツで下のたくさんのボールを運びたいと思います。  
何回運ぶとボールは無くなりますか。その数を調べて青色で○を書きなさい。

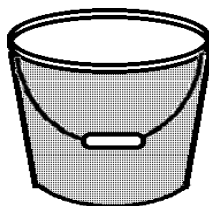
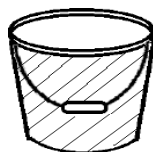
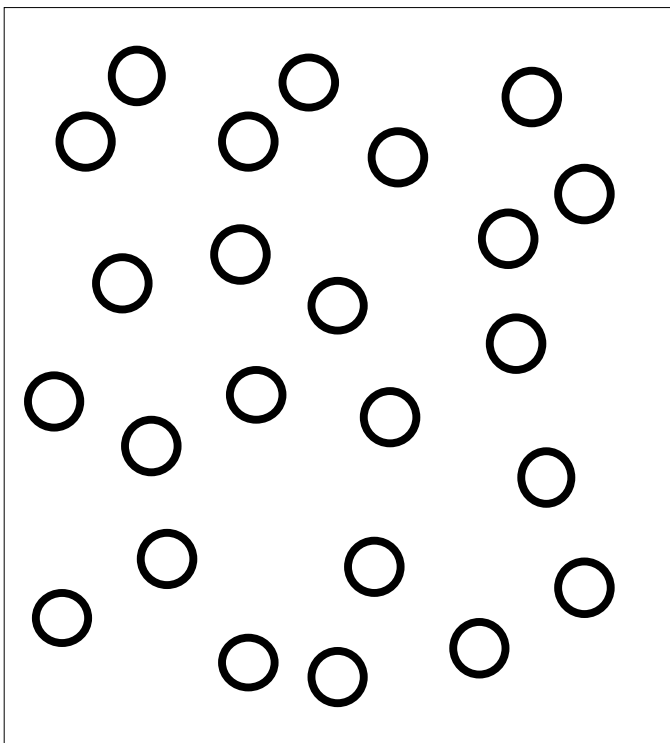



いままでの問題と少しちがうぞ~!!

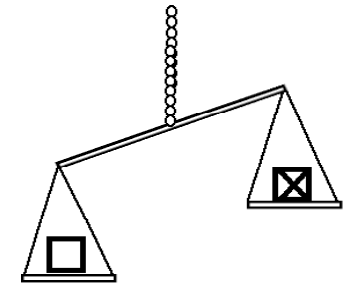
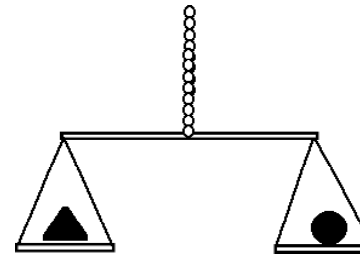
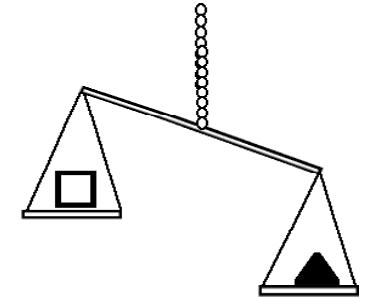
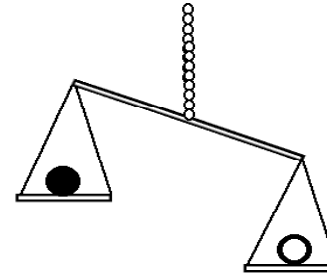
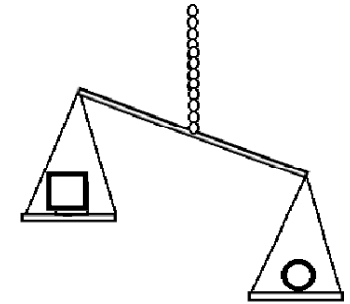
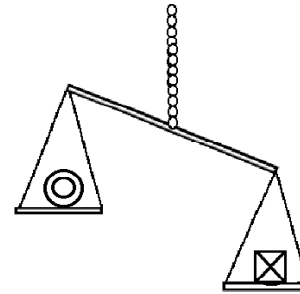
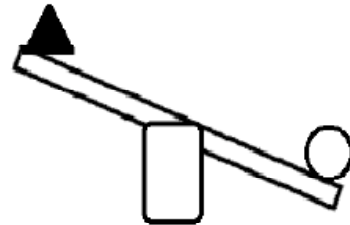
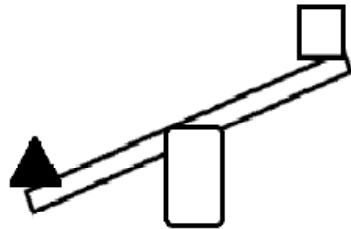
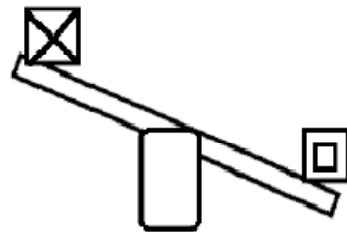
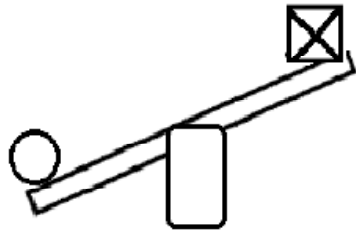
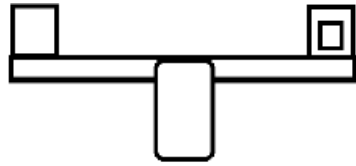

1番重い物に○を1番軽い物に×を枠の中の絵に緑色で付けなさい。

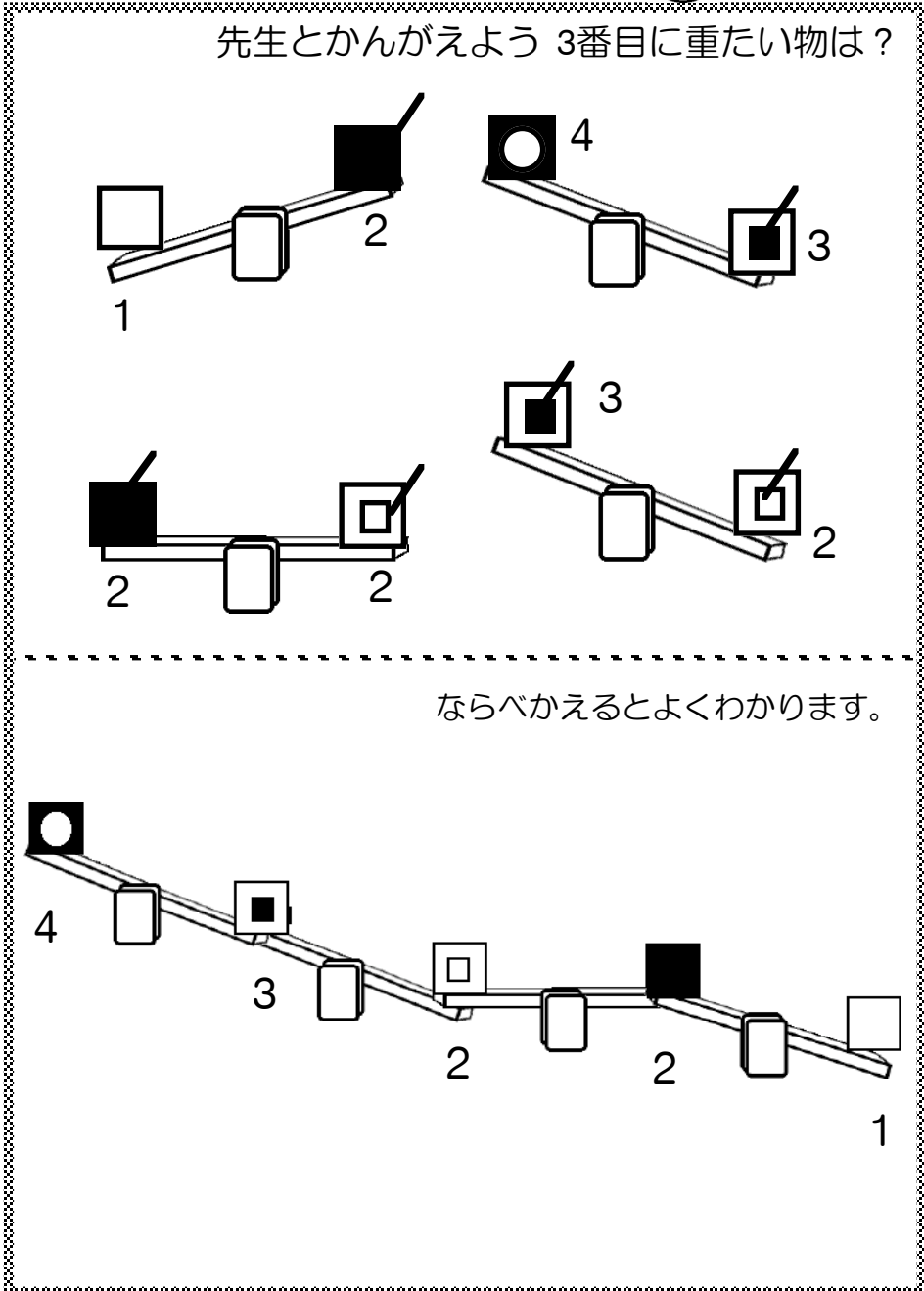
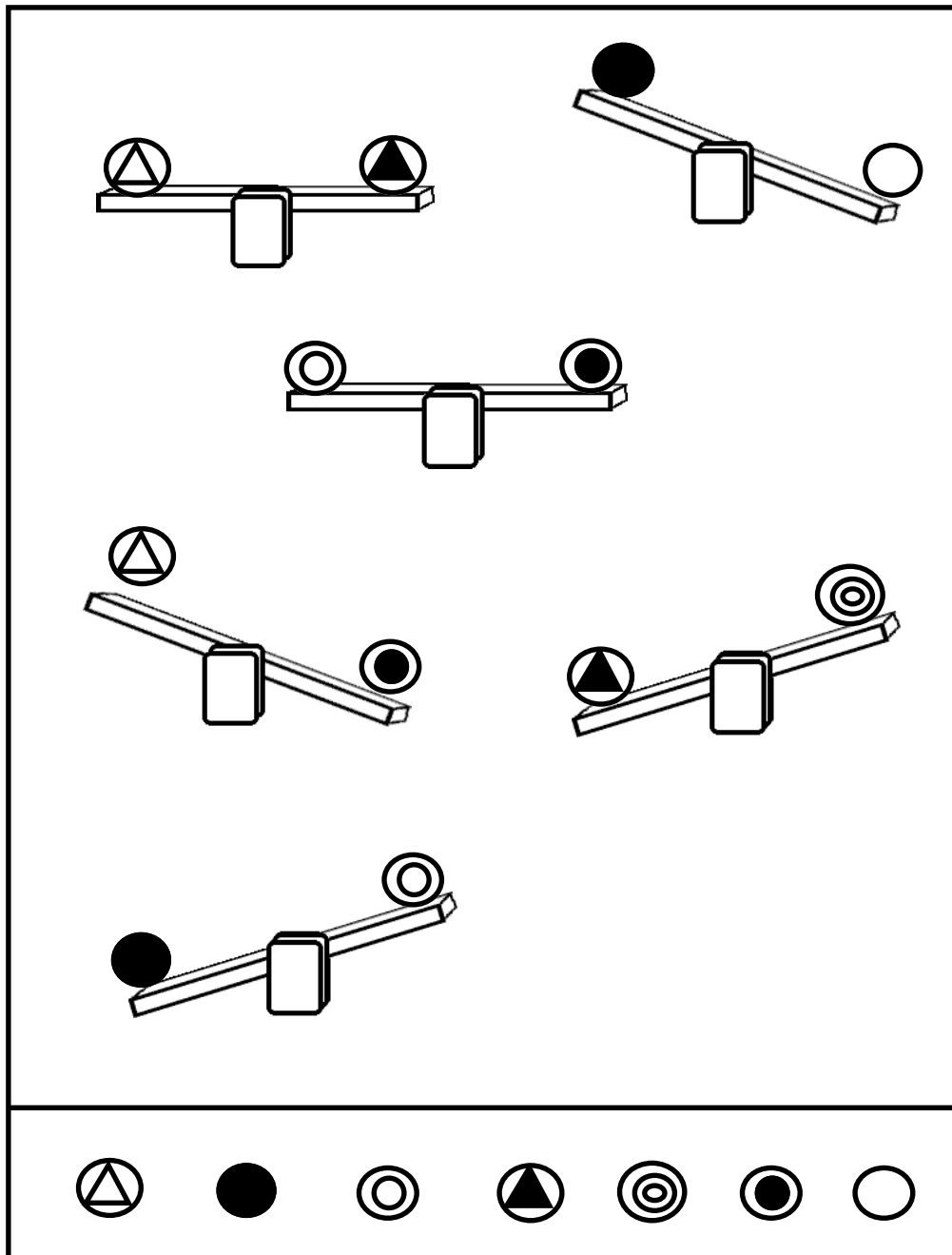

1番重い物に○を2番重い物×を枠の中の絵に緑色で付けなさい。



2番めに重い物に緑色で○を付けなさい。

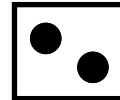
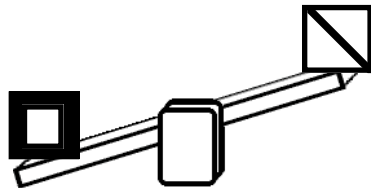
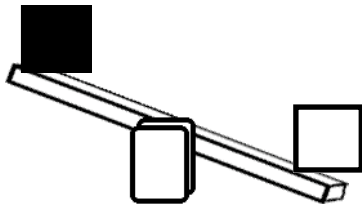
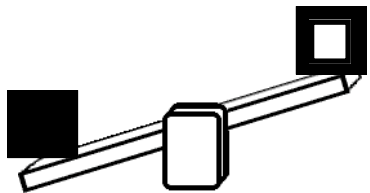
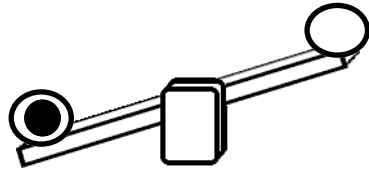
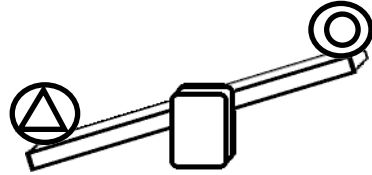
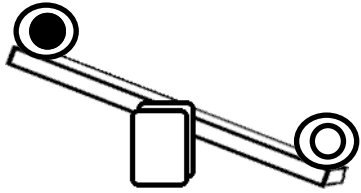

つりあっているよ

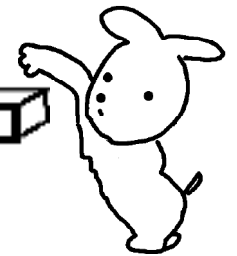
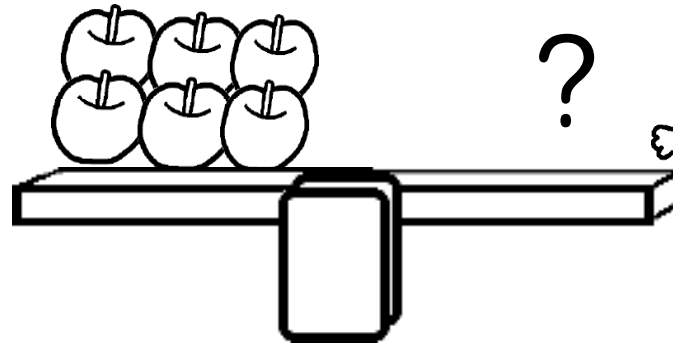
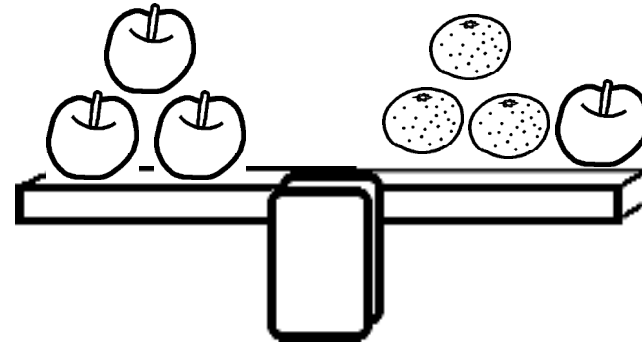

いくつみかんをのせると  
つりあうかな? 下のみかんに  
その数だけ緑色で○を付けなさい。







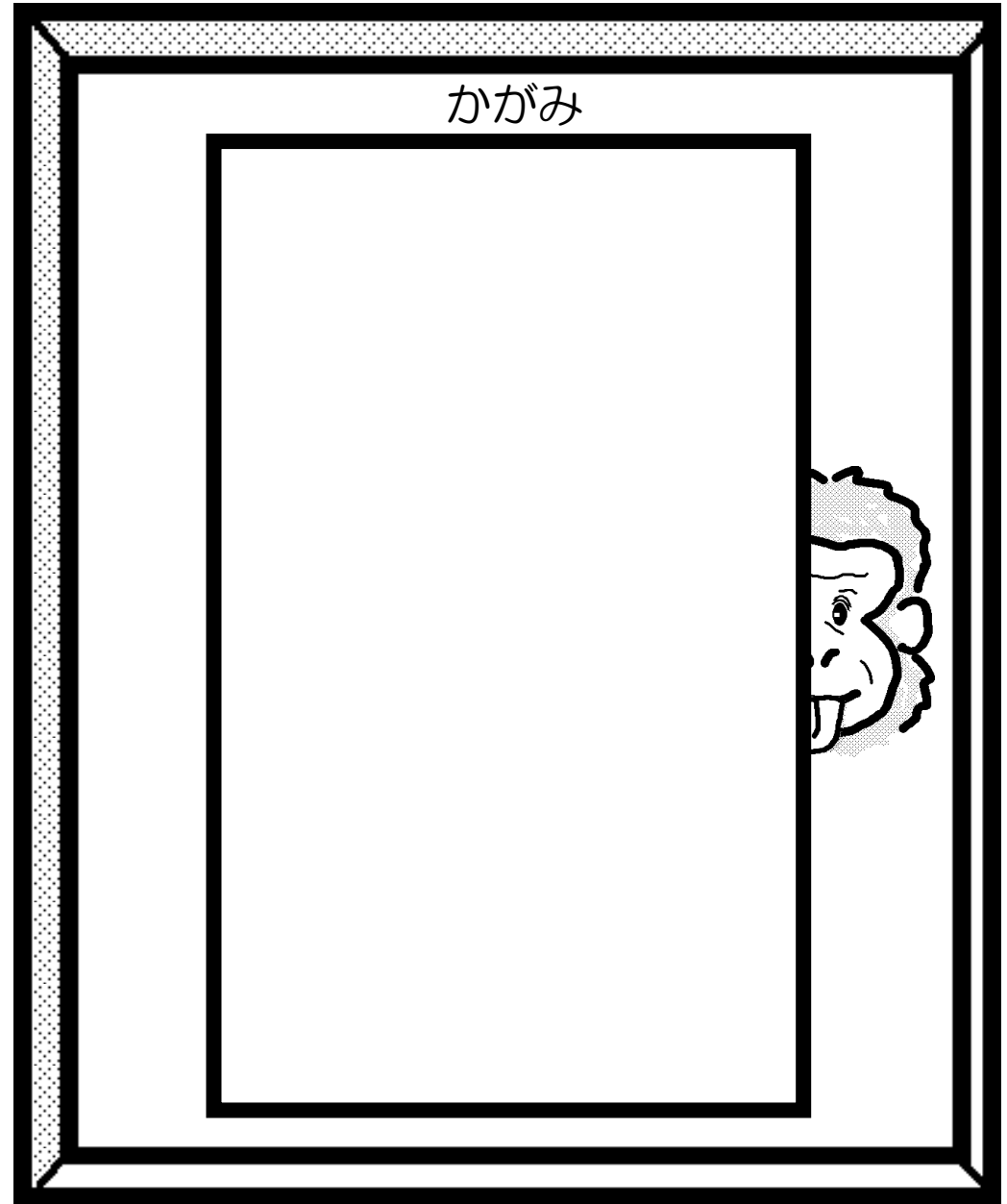
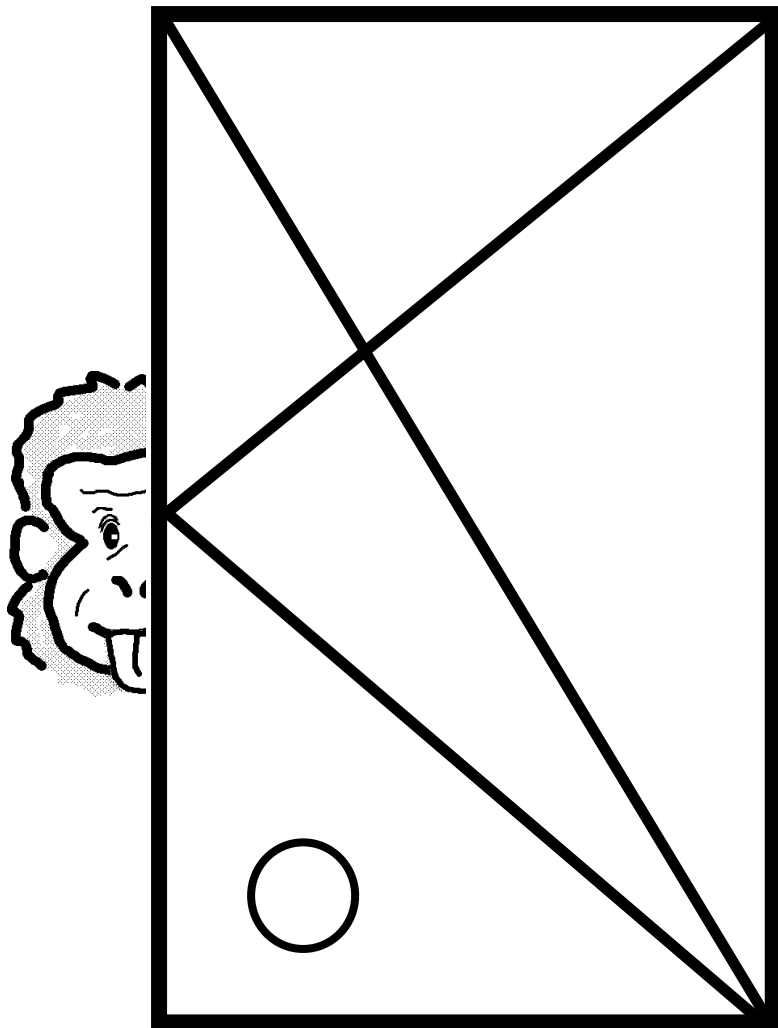

太陽の位置をみて正しい影に○を茶色で付けなさい。

さる君が持っているお手本をかがみにうつしました。白○や線を鉛筆で丁寧に書きましょう。



# 年長 ちぎりえ

信号機の色を調べて折紙を手で小さくちぎって糊で貼りましょう。

\*青色が緑色でもかまいません。

