















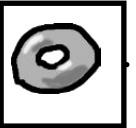

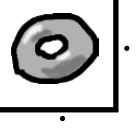





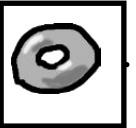

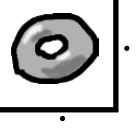





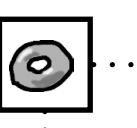
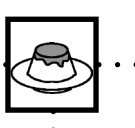

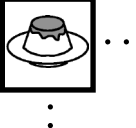
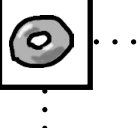
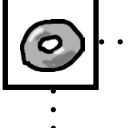
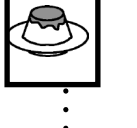

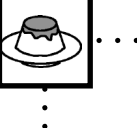
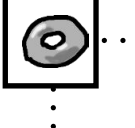
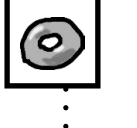
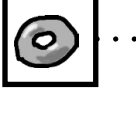
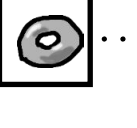

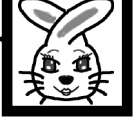

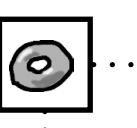
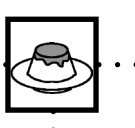

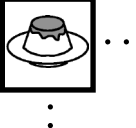
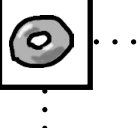
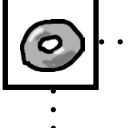
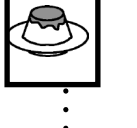

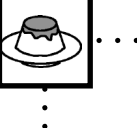
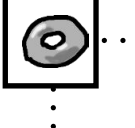
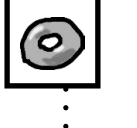
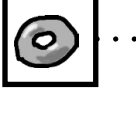
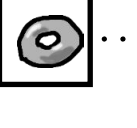

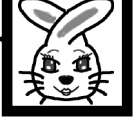

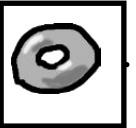

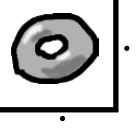





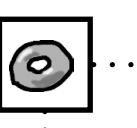
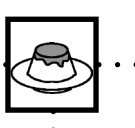

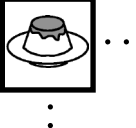
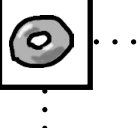
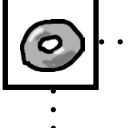
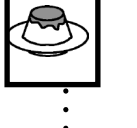

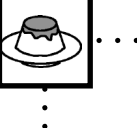
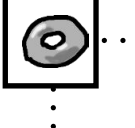
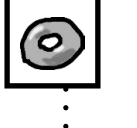
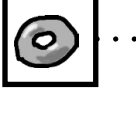
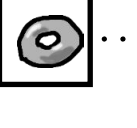

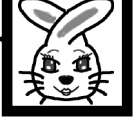

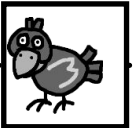

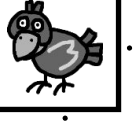
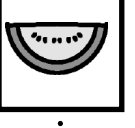

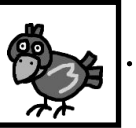

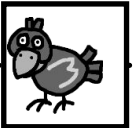

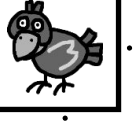
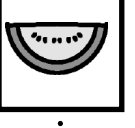

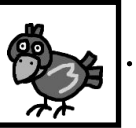

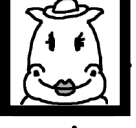
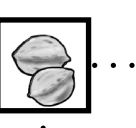
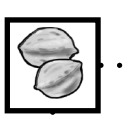
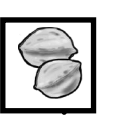

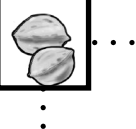
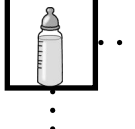
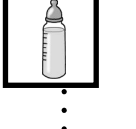
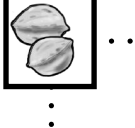
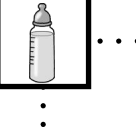

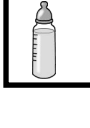
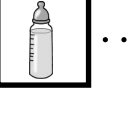
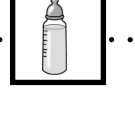
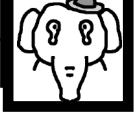
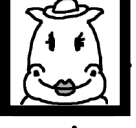
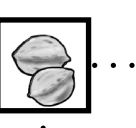
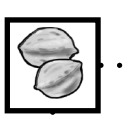
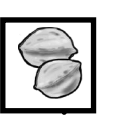

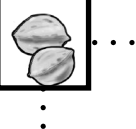
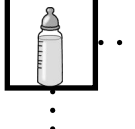
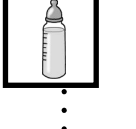
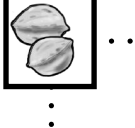
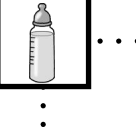

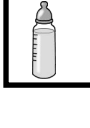
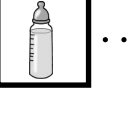
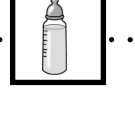
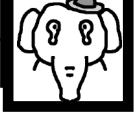

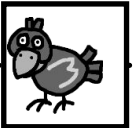
レインボー先生

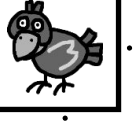
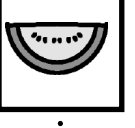

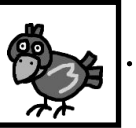
京都教育大学附属京都小中学校初等部 2015過去問

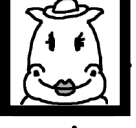
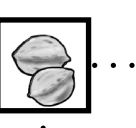
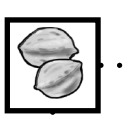
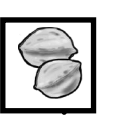

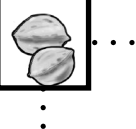
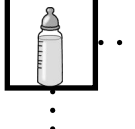
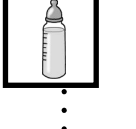
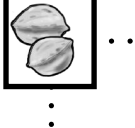
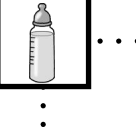
みんなで過去問に挑戦
絞った学習方法は的が小さくなり
当たりません。
いろんな学校の問題に挑戦すると
学力がアップ！

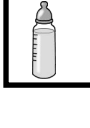
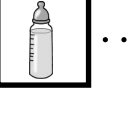
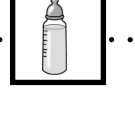
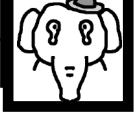
<div style="text-align: center;">  </div> <table style="width: 100%; text-align: center; border-collapse: collapse;"> <tr> <td style="border: 1px solid black; width: 33%; height: 60px;"></td> <td style="border: 1px solid black; width: 33%; height: 60px;"></td> <td style="border: 1px solid black; width: 33%; height: 60px;"></td> </tr> <tr> <td style="border: 1px solid black; width: 33%; height: 60px;"></td> <td style="border: 1px solid black; width: 33%; height: 60px;"></td> <td style="border: 1px solid black; width: 33%; height: 60px;"></td> </tr> <tr> <td style="border: 1px solid black; width: 33%; height: 60px;"></td> <td style="border: 1px solid black; width: 33%; height: 60px;"></td> <td style="border: 1px solid black; width: 33%; height: 60px;"></td> </tr> </table>										<div style="text-align: center;">  </div> <table style="width: 100%; text-align: center; border-collapse: collapse;"> <tr> <td style="border: 1px solid black; width: 25%; height: 60px;"></td> <td style="border: 1px solid black; width: 25%; height: 60px;"></td> <td style="border: 1px solid black; width: 25%; height: 60px;"></td> <td style="border: 1px solid black; width: 25%; height: 60px;"></td> </tr> <tr> <td style="border: 1px solid black; width: 25%; height: 60px;"></td> <td style="border: 1px solid black; width: 25%; height: 60px;"></td> <td style="border: 1px solid black; width: 25%; height: 60px;"></td> <td style="border: 1px solid black; width: 25%; height: 60px;"></td> </tr> <tr> <td style="border: 1px solid black; width: 25%; height: 60px;"></td> <td style="border: 1px solid black; width: 25%; height: 60px;"></td> <td style="border: 1px solid black; width: 25%; height: 60px;"></td> <td style="border: 1px solid black; width: 25%; height: 60px;"></td> </tr> <tr> <td style="border: 1px solid black; width: 25%; height: 60px;"></td> <td style="border: 1px solid black; width: 25%; height: 60px;"></td> <td style="border: 1px solid black; width: 25%; height: 60px;"></td> <td style="border: 1px solid black; width: 25%; height: 60px;"></td> </tr> </table>																
																										
																										
																										
																										
																										
																										
																										
<div style="text-align: center;">  </div> <table style="width: 100%; text-align: center; border-collapse: collapse;"> <tr> <td style="border: 1px solid black; width: 33%; height: 60px;"></td> <td style="border: 1px solid black; width: 33%; height: 60px;"></td> <td style="border: 1px solid black; width: 33%; height: 60px;"></td> </tr> <tr> <td style="border: 1px solid black; width: 33%; height: 60px;"></td> <td style="border: 1px solid black; width: 33%; height: 60px;"></td> <td style="border: 1px solid black; width: 33%; height: 60px;"></td> </tr> <tr> <td style="border: 1px solid black; width: 33%; height: 60px;"></td> <td style="border: 1px solid black; width: 33%; height: 60px;"></td> <td style="border: 1px solid black; width: 33%; height: 60px;"></td> </tr> </table>										<div style="text-align: center;">  </div> <table style="width: 100%; text-align: center; border-collapse: collapse;"> <tr> <td style="border: 1px solid black; width: 25%; height: 60px;"></td> <td style="border: 1px solid black; width: 25%; height: 60px;"></td> <td style="border: 1px solid black; width: 25%; height: 60px;"></td> <td style="border: 1px solid black; width: 25%; height: 60px;"></td> </tr> <tr> <td style="border: 1px solid black; width: 25%; height: 60px;"></td> <td style="border: 1px solid black; width: 25%; height: 60px;"></td> <td style="border: 1px solid black; width: 25%; height: 60px;"></td> <td style="border: 1px solid black; width: 25%; height: 60px;"></td> </tr> <tr> <td style="border: 1px solid black; width: 25%; height: 60px;"></td> <td style="border: 1px solid black; width: 25%; height: 60px;"></td> <td style="border: 1px solid black; width: 25%; height: 60px;"></td> <td style="border: 1px solid black; width: 25%; height: 60px;"></td> </tr> <tr> <td style="border: 1px solid black; width: 25%; height: 60px;"></td> <td style="border: 1px solid black; width: 25%; height: 60px;"></td> <td style="border: 1px solid black; width: 25%; height: 60px;"></td> <td style="border: 1px solid black; width: 25%; height: 60px;"></td> </tr> </table>																
																										
																										
																										
																										
																										
																										
																										

左上の動物から右下の動物まで今から言う順番に線を引きます。よく聞いて覚えてください。

サイコロ1の問題 ドーナツ→キャンディ→キャンディ 引きましょう。







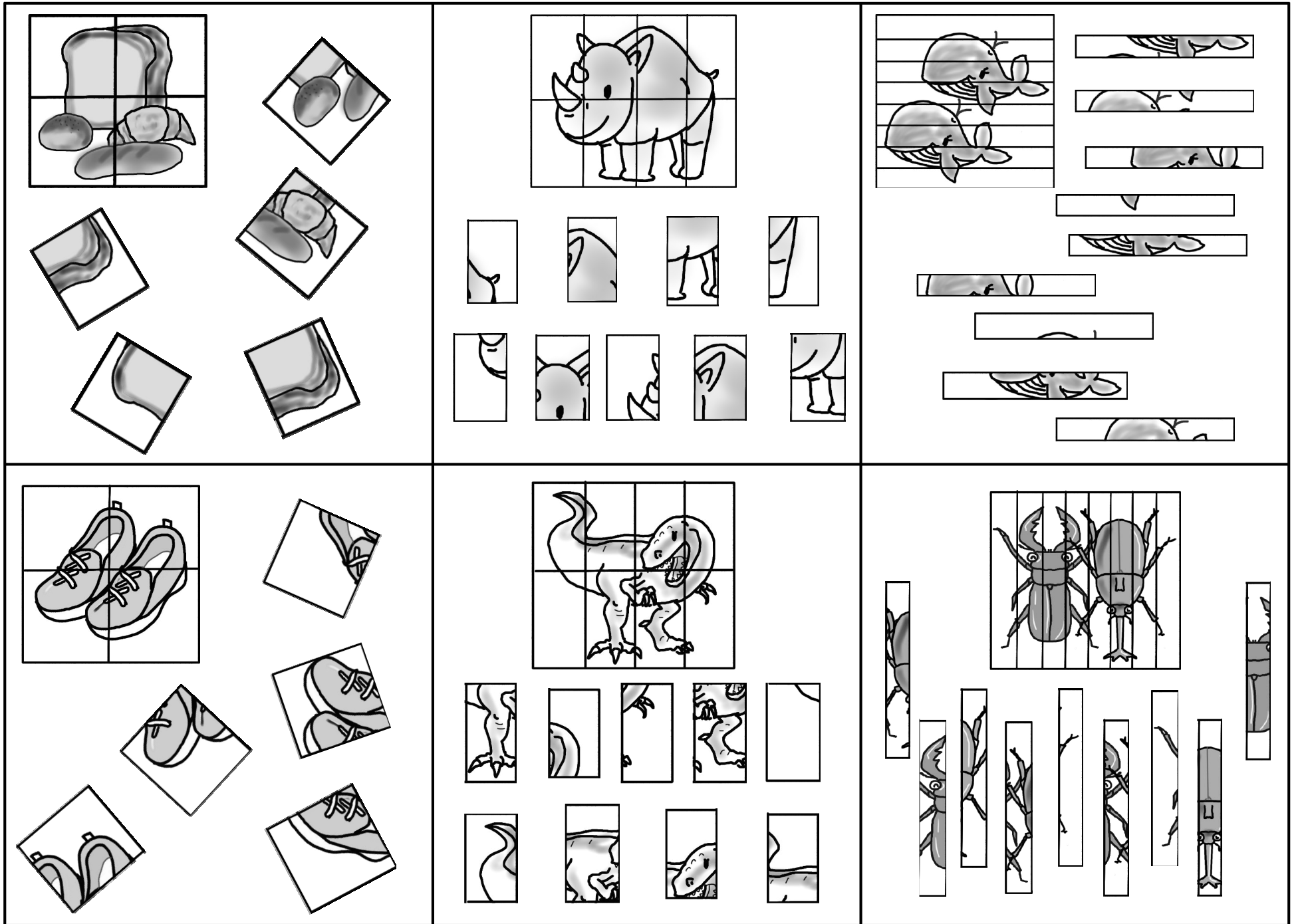

















































































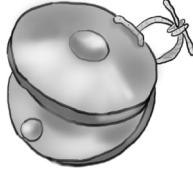





































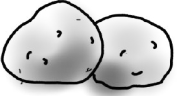

























































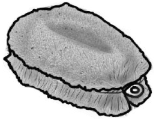

















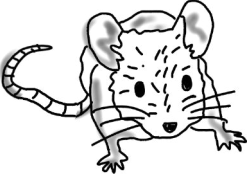
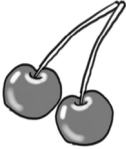



























サイコロ2の問題 スイカ→カラス→カラス→カラス→スイカ 引きましょう。

サイコロ3の問題 プリン→ドーナツ→プリン→ドーナツ→ドーナツ 引きましょう。

サイコロ4の問題 クルミ→クルミ→ミルク→ミルク→ミルク 引きましょう。









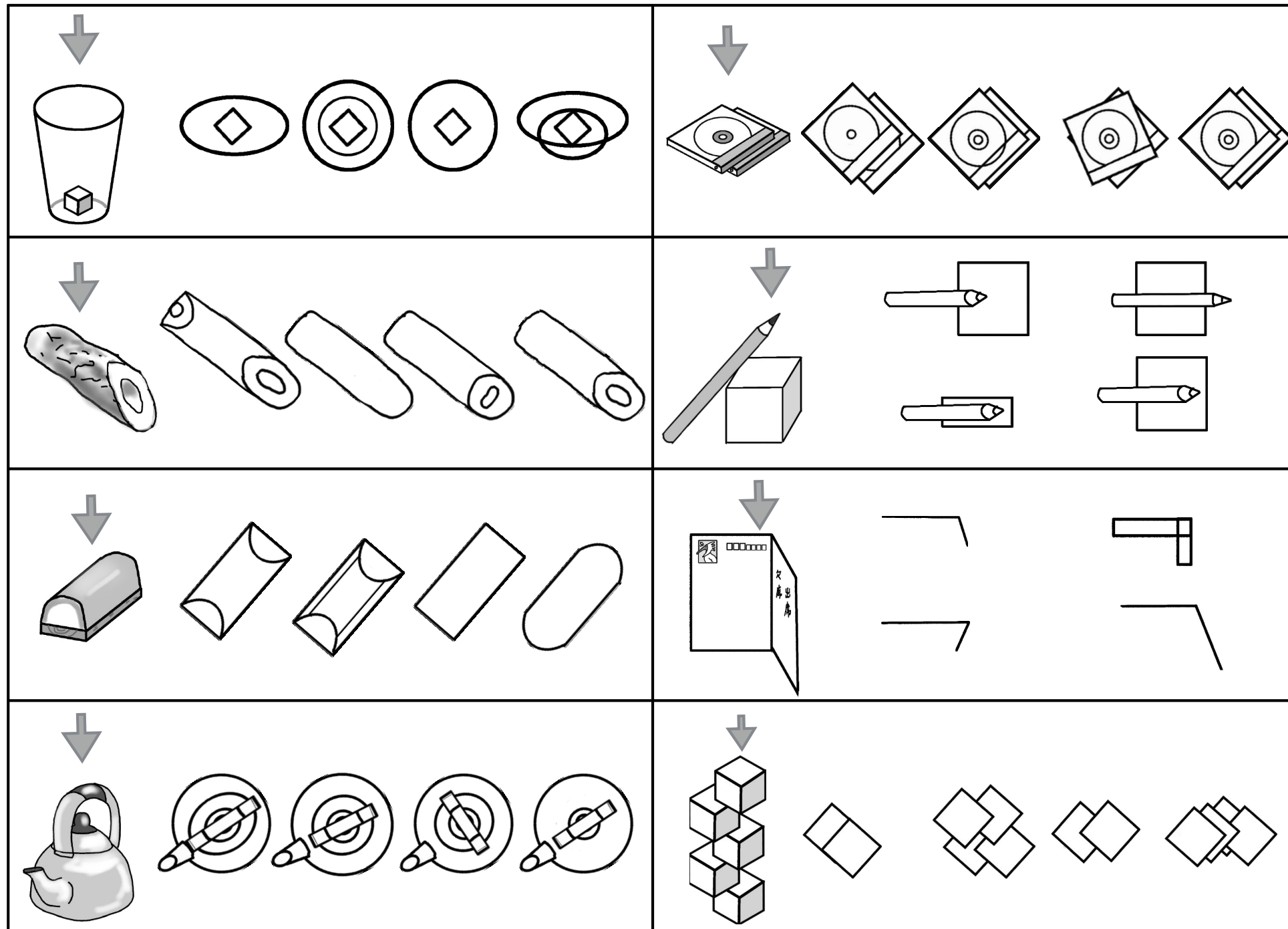





















お手本を作るのに1つだけ使わないパズルがあります。見つけて○をつけましょう。

















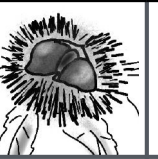

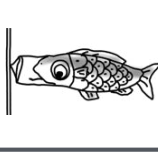



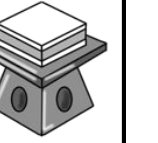

	<p>*</p> <table border="1"> <tr> <td></td> <td></td> <td></td> </tr> <tr> <td></td> <td></td> <td></td> </tr> <tr> <td></td> <td></td> <td></td> </tr> </table>												<table border="1"> <tr> <td></td> <td></td> <td></td> </tr> <tr> <td></td> <td></td> <td></td> </tr> <tr> <td></td> <td></td> <td></td> </tr> </table> <p>*</p>										
																							
																							
																							
																							
																							
																							
	<table border="1"> <tr> <td></td> <td></td> <td></td> </tr> <tr> <td></td> <td></td> <td></td> </tr> <tr> <td></td> <td></td> <td></td> </tr> </table> <p>*</p>												<p>*</p> <table border="1"> <tr> <td></td> <td></td> <td></td> </tr> <tr> <td></td> <td></td> <td></td> </tr> <tr> <td></td> <td></td> <td></td> </tr> </table>										
																							
																							
																							
																							
																							
																							
	<table border="1"> <tr> <td></td> <td></td> <td></td> </tr> <tr> <td></td> <td></td> <td></td> </tr> <tr> <td></td> <td></td> <td></td> </tr> </table>												<table border="1"> <tr> <td></td> <td></td> <td></td> </tr> <tr> <td></td> <td></td> <td></td> </tr> <tr> <td></td> <td></td> <td></td> </tr> </table>										
																							
																							
																							
																							
																							
																							
	<table border="1"> <tr> <td></td> <td></td> <td></td> </tr> <tr> <td></td> <td></td> <td></td> </tr> <tr> <td></td> <td></td> <td></td> </tr> </table>												<table border="1"> <tr> <td></td> <td></td> <td></td> </tr> <tr> <td></td> <td></td> <td></td> </tr> <tr> <td></td> <td></td> <td></td> </tr> </table>										
																							
																							
																							
																							
																							
																							

左の絵から右の絵までしりとりができるようにするには、真ん中の、どの絵を使うとよいですか。
3つ選んでその絵に○をつけましょう。

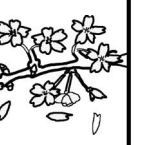

5 左の物を上から見るとどのような形に見えますか。○をつけましょう。

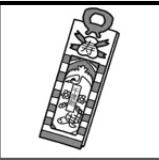
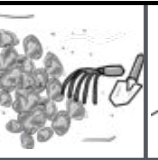
				
○	△	□	◎	
				
				
				
				
				

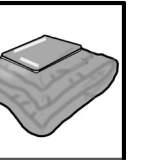
				
□	◎	○	△	
				
				
				
				
				

京都教育大学附属京都小中学校初等部2015過去問 (問3取り)

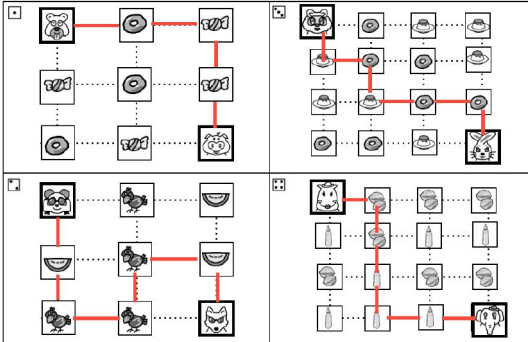

左の動物から右下の動物まで順番に順番に移動します。よく見て見てください。
 マウスは1回、鳥は2回、うさぎは3回、かめは4回、へびは5回、ももは6回、うぐいすは7回、うさぎは8回、くまは9回。
 マウスは1回、鳥は2回、うさぎは3回、かめは4回、へびは5回、ももは6回、うぐいすは7回、うさぎは8回、くまは9回。

2 

京都教育大学附属京都小中学校初等部2015過去問 (問3取り)

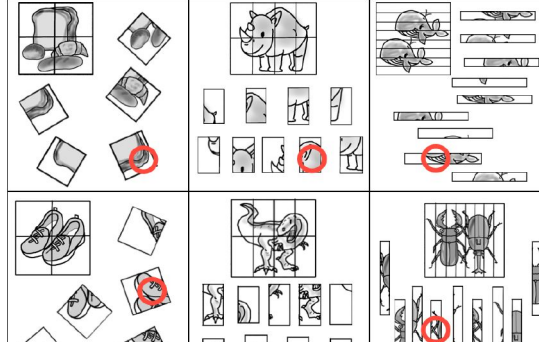

お茶を飲むのに1つだけ足りないものがあります。見つけてください。

3 

京都教育大学附属京都小中学校初等部2015過去問 (しりとり)

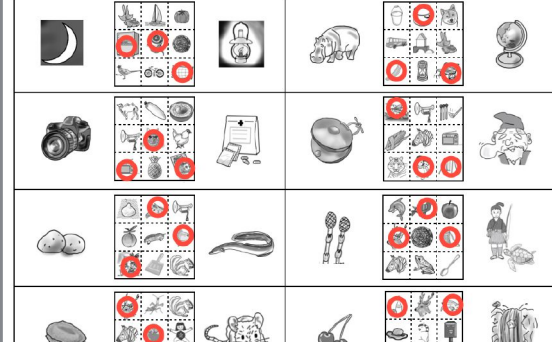

4 

京都教育大学附属京都小中学校初等部2015過去問 (上からの順)

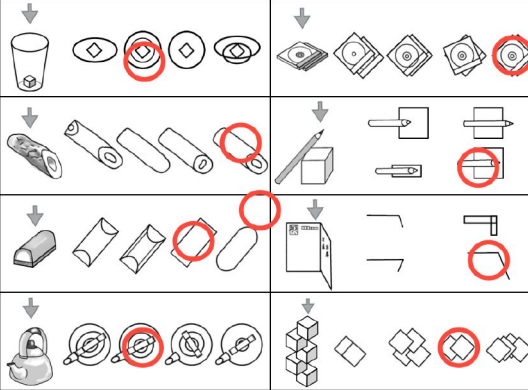

5 

京都教育大学附属京都小中学校初等部2015過去問 (伊能祝用印刷)

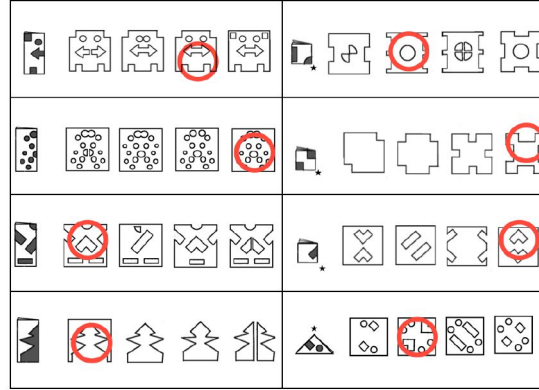

6 

京都教育大学附属京都小中学校初等部2015過去問 (赤文字2x2)

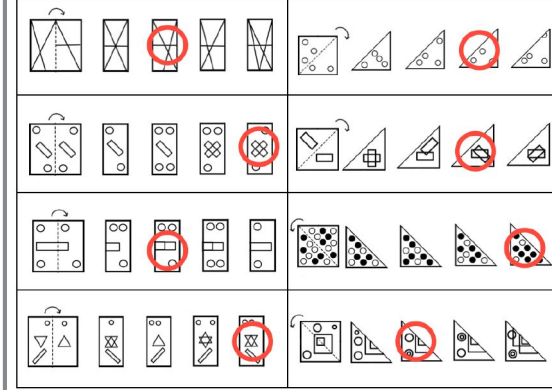

7 

京都教育大学附属京都小中学校初等部2015過去問 (お茶)

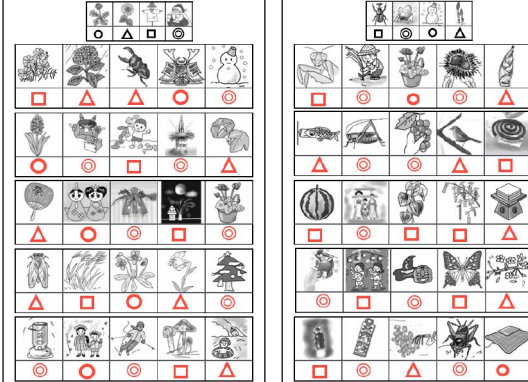

8 

国立はバランス！
 ペーパー以外の絵画・製作・運動・行動観察はどれも大切です

